

# AUTONOMOUS MOBILE ROBOTS



FEATURES//  
ETHERNET 1/0  
IN THE AGE OF IIOT

DYNAMIC MEASUREMENT  
AND CALIBRATION OF MECHANICAL  
SENSORS: NEW SOFTWARE

STRONG M&A MARKET  
ROGER BUCKLEY, CORPORATE FINANCE  
PARTER, BDO LLP SAYS THE FEEL  
GOOD FACTOR CONTINUES

OCTOBER\_2018\_ISSUE EIGHT

# PRECISION

## ***FS Engineer & Technician (TÜV Rheinland) Certificate Training***

***Last chance for courses in 2018***



***(New) Introduction to Functional Safety:***

**(The ideal one day workshop preparation for the FS Engineer course)**

**Aberdeen: 3 December**

***FS Eng. SIS:***

**Aberdeen: 10/11 + 17-18 November (Weekends)  
4-7 December**

**London: 22-26 October**

***FS Technician 2018:***

**Aberdeen: 15-18 October**

***Our 2019 schedule will be published shortly, please contact us for more details.***

C & C Technical Support Services is an accepted course provider of the TÜV Rheinland Functional Safety Training Program.



# FLYING THE FLAG FOR INSTMC

The next nine months will be one of the best opportunities for many years for the Institute to raise its profile as the professional body for measurement, automation and control.

On 3rd September, we were proud to host the IMEKO World Congress, the triennial international measurement meeting. This was the first IMEKO Congress in the UK in over 40 years, and all the signs indicate that it made an international mark. Two Nobel prize winners were among the keynote speakers, and over 500 papers were accepted for presentation across the four days. Practically every major thought leader in measurement science was present at the meeting venue in Belfast.

We also used IMEKO to launch the first ever Festival of Measurement, which runs until the new SI system

is inaugurated on International Metrology Day, 20th May 2019. From that date all seven fundamental units of measurement will be defined by universal constants such as the speed of light and Plank's constant: existing national and international prototypes of the kilogram and metre etc will be for reference purposes only. The 23 million second duration of the Festival embraces school competitions, science museum displays, Royal Institution lectures, a government-hosted seminar for industry leaders and a wealth of other national and regional activities.

Our newly formed and re-formed Special Interest Groups are making their presence felt. We have nine SIGs at various stages of development – some already active and others embryonic, but all with a wide cross section of interest, as judged by the number of members signing up to be involved. Some SIGs are organising specialist events in their areas; others are collaborating with related bodies to pursue priorities with government, regulators and standards agencies.

Our Local Sections in the UK and internationally continue to be the first point of contact for many

members, and it is encouraging to hear of growth in numbers and activities in some areas – Hong Kong being a particular example. Connections between sections and their local colleges and universities are proving to be a great way to involve younger engineers and scientists, and the number of our student members is increasing. A recent focus group meeting here identified opportunities for our Companion Company members to become more involved with local sections and HEI institutions, a three-way interaction to the benefit of all.

A good question, especially with a name like ours, is how to measure the impact of all this activity. There are various obvious metrics, but for me success will be that I announce whom I represent, and the response is recognition, not a request for clarification. I am keeping a score.

**Patrick Finlay PhD CEng**  
Chief Executive Officer



# CONTENTS

## FEATURES

### ETHERNET I/O IN THE AGE OF IIOT



Data is everywhere. The amount of information processed every day is mind boggling. We are constantly reminded, often alarmingly so, that the age of Big Data is our epic panacea.

**10-13**

### DYNAMIC MEASUREMENT AND CALIBRATION OF MECHANICAL SENSORS: NEW SOFTWARE



Sascha Eichstädt, PTB, Ian Smith, NPL and André Schäfer from HBM discuss PyDynamic, new software which supports dynamic measurement.

**14-16**

### AUTONOMOUS MOBILE ROBOTS

**6-8**

Supporting lean approaches to production on today's more dynamic plant floors are Autonomous Mobile Robots.



# BDO NEWS

## STRONG M&A MARKET ROGER BUCKLEY, CORPORATE FINANCE PARTNER, BDO LLP SAYS THE FEEL GOOD FACTOR CONTINUES

The second quarter of 2018 saw 642 deals complete in the UK, a notable increase from last quarter's 560 deals and a rise of 7% compared with the same period last year, according to the latest analysis from accountancy and business advisory firm BDO LLP.

**18-19**

# OPINION PIECE



## WHY THE NEW EPRIVACY REGULATION MUST BE ON YOUR CORPORATE RADAR

Now that the hype and fury over the new General Data Protection Regulation (GDPR) has died down, businesses will have to get their heads around another European Union edict, by the end of 2018 or early 2019, in the shape of the ePrivacy Regulation (ePR).

**20-21**

# REGULARS

## MEET THE TEAM

**22**

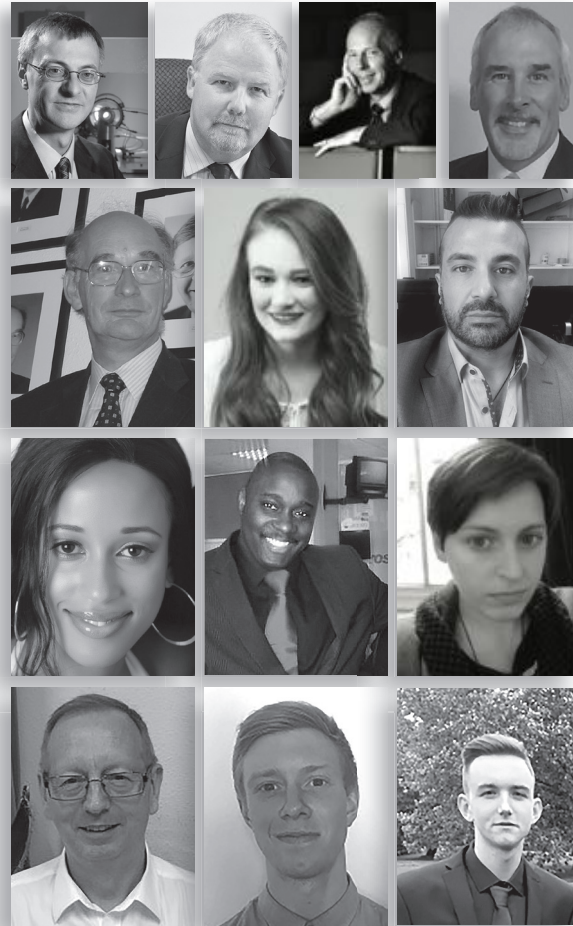

# PRECISION

The magazine of the Institute of Measurement and Control

Published by: Institute of Measurement and Control  
87 Gower Street, London, WC1E 6AF  
T: 0+ 44 (0) 20 7387 4949  
www.instm.org  
www.facebook.com/instm  
www.linkedin.com/groups/117672

Chief Executive  
Patrick Finlay PhD CEng  
E: ceo@instmc.org

Design, print & mail fulfilment  
by HMCA Services Ltd  
Tel: 01423 866985  
Email: enquiries@hmca.co.uk

Advertising sales in partnership  
with HMCA Services Limited  
Carol Rees - Allott & Associates Ltd  
Telephone: 01423 867264  
Email: carol@allottandassociates.co.uk







# AUTONOMOUS MOBILE ROBOTS



Supporting lean approaches to production on today's more dynamic plant floors are Autonomous Mobile Robots.

As manufacturers embrace lean approaches to their operations, there is continual evaluation of any opportunities to optimise production. Even in highly automated facilities, material handling often remains a manual, inefficient process and automating material transportation to reduce production bottlenecks and deploy valuable human workers more effectively has been a challenge.

Automated guided vehicles (AGVs) are no longer able to provide the flexibility needed in today's agile manufacturing processes. However, new sensor and software technologies are making autonomous mobile robots (AMRs) a good solution for often unpredictable and changing production layouts and dynamic work environments.

## Manual transportation

Manual transportation requires workers to leave their stations to push carts loaded with materials between manufacturing processes and the stockroom, and can result in production backlogs and idle workers as they wait for assemblies and parts to be delivered. Plant set-up is often dynamic, with new production cells and processes that must be supported and people, equipment, pallets, and other obstacles can appear in what used to be open passageways. Any automated material transportation approach needs to be flexible and adaptable without additional cost or disruption to processes, not to mention safe for operation around employees. That flexibility also means that automated material handling must be easy to learn, programme, deploy, and redeploy in-house to ensure that the chosen approach can keep up-to-date with requirements cost-effectively.

Traditional AGVs move materials using fixed routes guided by permanent wires, magnetic strips,

or sensors embedded in the plant floor. However, those systems are inflexible and do not fit with the trend for more dynamic manufacturing floors. If manufacturing processes change, the facility must be updated again—and if people or material temporarily block the AGV's route, it simply stops until the way is cleared. In contrast, autonomous mobile robots (AMRs) are designed to work within dynamic and changing environments. They offer the flexibility, safety, and cost-effectiveness that allows companies of any size to automate and optimise material handling.

An AMR navigates via sensors, cameras, and software built into the robot itself, without the need for external sensors or guides. Once the robot has learned its surroundings – either by uploading a facility blueprint or by piloting the robot around the plant to develop its own map – it will recognise its surroundings and can take the most efficient route to its destination autonomously, safely avoiding obstacles and people.



Any automated material transportation approach needs to be flexible and adaptable without additional cost or disruption to processes, not to mention safe for operation around employees.





Magna-Power, a US-based manufacturer of power products, deployed two Mobile Industrial Robots (MiR) AMRs to move parts and assemblies from the stockroom and through its vertically integrated manufacturing floor. “One thing that was pretty astonishing for me is that the MiR robot was delivered and 15 minutes later it was unpacked and on the floor,” said Adam Pitel, VP of operations at Magna-Power. “In another 15 minutes, I’m controlling it with my mobile phone, and within two hours it is travelling from point to point in our building, after uploading a schematic of our facilities.”

The fast and easy integration of AMRs make them capable of adding new efficiencies almost immediately. With low initial costs and fast optimisation of processes, they offer remarkably fast return on investment – often in less than six months.

### Efficiency gains

AMRs can bring efficiency gains to a number of operations related to production and material handling. As businesses grow, AMR implementation can expand simultaneously with minimal additional costs. Moreover, the AMR is collaborative and can be used in nearly any situation where employees are currently spending time pushing carts or making deliveries. Automating these low-value tasks means that employees can focus on higher-value activities. At Magna-Power the implementation of the two MiRs has freed the equivalent of three full-time employees, who can now focus all their attention on the tasks they were hired to do. “The purpose of the robot is not to replace employees, but to make them more efficient with their time,” explains Grant Pitel, VP of engineering at Magna-Power. “Now they can focus on the things that we can’t get a robot to do.”

AMRs can perform the monotonous and repetitive tasks of material transportation without breaks that can disrupt the assembly process.

NewForm, a manufacturer of Italian-designed bath taps and fittings, is seeing these benefits with its two MiR robots.

Damiano Marconi, technical assistant at NewForm, said: “Now our lines are active on a 24/7 ‘lights out’ basis, because they are automatically loaded and unloaded.” Moreover, the MiRs are integrated with the production planning system and provide a real-time overview of materials. “We can guarantee a real-time production control. The very simple integration software can easily communicate with both our machine tools and our data server, so we can easily track every piece, its position and condition in real-time.”

Modern manufacturing environments can no longer be dependent on costly, inflexible legacy technologies. Nor can they afford to continue the unproductive manual transportation of materials, especially in today’s tight labour market. Autonomous mobile robots now offer an agile alternative to AGVs or manual delivery, providing flexibility, cost-effectiveness, return on investment, and productivity optimisation.



One thing that was pretty astonishing for me is that the MiR robot was delivered and 15 minutes later it was unpacked and on the floor,” said Adam Pitel, VP of operations at Magna-Power. “In another 15 minutes, I’m controlling it with my mobile phone, and within two hours it is travelling from point to point in our building, after uploading a schematic of our facilities.





# THE INSTITUTE OF MEASUREMENT AND CONTROL IS PROUD TO ANNOUNCE THAT IT WILL BE HOSTING THE NATIONAL FESTIVAL OF MEASUREMENT

The Festival will start in September 2018 at the IMEKO World Congress and run until World Metrology Day 2019.

On 20th of May 2019, all the SI units will finally be based on measurable physical constants and the last remaining measurement artefact (the kilogram) will no longer be needed.

To celebrate this change, InstMC wants to spend the time leading up to the SI redefinition highlighting the importance of measurement in all areas of life.



*Festival of*  
**MEASUREMENT**



# ETHERNET I/O IN THE AGE OF IIOT

Data is everywhere. The amount of information processed every day is mind boggling. We are constantly reminded, often alarmingly so, that the age of Big Data is our epic panacea.

Conditioned like Pavlov's Dogs, we now expect and seek more and more data, speedier access and technology via IOT, IIOT, 5G's rollout, MIMO Wi-Fi, Industry 4.0.

For the commercial and private users, the blinding frequency of advancements in access to data seems synonymous with the sun rising and falling: it will just happen. But here in the industrial automation industry, speed and access are only part of the equation. As the saying goes, "Rubbish in, rubbish out": poor quality data yields poor quality results. With our fixation on speed and unlimited access to a massive and growing cloud of digital data, the desire for convenient access has overshadowed the importance of signal integrity at the analogue level. Analogue may seem boring and slow, often equated to the "Stone Age" compared to digital data. In our industrial world, however, it is

the integrity of the initial analogue measurement that has direct impact on the quality of results.

It is here where we have to look through the cloud of data convenience and not forget that while industrial Ethernet is winning out over proprietary industrial communication networks and topologies, signal measurement integrity at the I/O level is still of utmost importance.



## Ethernet Ubiquity

It is nearly impossible to find a Fortune 500 company that has not installed plenty of Ethernet and fibre backbones throughout their corporate campuses and manufacturing facilities. Even small, privately held companies have adopted the once thick and cumbersome coax called Ethernet. Now, with UTP (Unshielded Twisted Pair) and fibre being utilised at the physical and data link layers (1 and 2 of the OSI Model), Ethernet has gained unfettered admission right onto the plant floor.

Ethernet's ease of installation and low cost has made it the de-facto standard for networking at both the industrial and corporate level. Speedy broadband connections are now affordable for use by just about anyone. Industrial RJ-45 connectors, patch cables, hardened switches and network cards are as inexpensive and prevalent as desktop calculators. You would be hard pressed to find a manufacturing facility constructed in this millennium that didn't have fibre or UTP cable embedded all throughout its walls.

It was once proclaimed by many that "Ethernet's place is in the front office. It will never make it out to the plant floor". While Ethernet's argued impediments range from lack of determinism to limited transmission distances, we now know that its capacity for determinism, when properly designed with switches and smaller collision domains, is manageable. Distance limitations can be overcome by the use of fibre, repeaters, and even wireless systems.



## Sensor-to-ERP-to-Cloud

Information is power. The ability to gather time-critical information, digest it, and react upon it is the only way manufacturing companies have to stay in touch with customers needs and demands. Without it companies implode. Today, ERP (Enterprise Resource Planning) systems exist in almost all companies. Whether packaged or custom, their purpose remains the same: to compile data for examination and decision-making. Initially these reports were "Front Office" reports. Today they consist of the last widget or batch that just came out of the production 15 minutes ago. This data typically comes from a MES (Manufacturing Execution System) package where it was obtained through a SCADA system via a PLC, BPCS or remote I/O device.

The lower half of the communication tree is where the difficulty lies. Data needs to get from the bottom of the organisation to the top, efficiently. While Ethernet ties these upper level systems together, many distributed I/O communication networks use proprietary protocols. With Ethernet-enabled I/O, many of these difficult layers can be circumvented by tying directly to upper level systems via FTP, HTML, and even OPC over Ethernet.

## Protocol Medley

With many twisted pair and coax networks, you are locked into using only one particular protocol simultaneously. For instance, if you are running Modbus/RTU over twisted pair, you cannot transmit any other protocol over the same

twisted pair unless you first stop the system's Modbus Master from polling the Modbus slave(s) to allow communication of the other protocol.

Alternatively, by using Ethernet I/O you can have several protocols operating over the same Ethernet physical layer. For example, suppose you want to take plant floor data to a relational database while also viewing this data with your browser, and historically trending it with your HMI. In the Modbus/RTU example, you would have to go through some type of gateway and/or combination of OPC servers and HMI's to accomplish this.

However, with an Ethernet remote I/O system that speaks Modbus/TCP, you can have an embedded web server and an OPC server that allow all of this data to be requested simultaneously over the same UTP or fibre cabling with no additional communication gateways involved. In short, Ethernet allows various protocols to co-exist over Ethernet at the same time. TCP, IP, UDP, SNMP, Modbus/TCP, HTML, SMTP and OPC can all operate in parallel, often in concert. This provides a compelling argument for preventive maintenance teams to diagnose and troubleshoot plant operations and activity quickly.

## Embedded Web Servers to the Rescue

Many Ethernet I/O systems have embedded FTP (File Transfer Protocol) servers and web (HTML) servers that can be used for real time viewing of data, historical collection, and configuration of I/O system. Ever tried to quickly take a look into a PLC that is not Ethernet-based without using PLC programming software or a customer HMI screen? Chances are you haven't because most traditional PLC systems require one or the other.

Many simple applications need an I/O system that can monitor just one or two critical points every so often, perhaps for troubleshooting. Ethernet I/O systems with built

in web servers allow anyone with access to the intranet to use Internet Explorer or a similar web browser to view real time data without paying for a costly HMI node or site license. Furthermore, embedded web servers allow for WAN access to real time data from anywhere in the world. Security considerations must, of course, be reviewed to determine the need for network encryption and security paraphernalia.

### Protocol Considerations

While Ethernet gives end users more power and flexibility, don't make the mistake of presuming that because it's on Ethernet, it will easily communicate with everything else that is on Ethernet. Ethernet provides a framework of rules for the physical connections, and rules about "who can talk when". Layer 7 of the OSI model, which refers to the application layer, is probably the most important layer of all because this is where the protocol is defined.

An I/O system and host system that both operate over Ethernet may never be able to communicate with one another. This is because the protocol chosen by the Ethernet I/O vendor determines how easily your connectivity will be with other "off the shelf" or vendor supplied software. Protocols like Modbus/TCP, Ethernet/IP, HSE and OPC are some of the more popular "open" protocols available today. Almost all HMI vendors and control system vendors support one or more of these protocols.

Be wary of vendors pushing their own Ethernet proprietary protocol. It may end up costing you a lot of time and money when you ultimately run into messy compatibility issues. In today's economy, "cost of ownership" has been replaced with "cost of entry". Projects are evaluated and won based on the upfront turnkey cost rather than looking at the long-term cost of maintaining the system after installation and commissioning. When choosing Ethernet I/O, be sure that your vendor is not pushing you

## Ethernet provides a framework of rules for the physical connections...

into the dreaded, and expensive, corner of proprietary.

### Plant Floor Expectations – Trash-In Entry Point

Installing Ethernet I/O in clean, cool and non-hostile environments presents few obstacles. But even when the I/O itself resides in comfortable conditions, great lengths must still be taken to protect and isolate UTP and fibre backbones from noise, heat and vibration.

Many I/O systems are now installed in harsh conditions in locations where field mount instrumentation has traditionally been installed. This includes environments where high and low temperatures and RFI/EMI levels may exist. Therefore, it is imperative that the Ethernet I/O

systems and accessories selected are up to the task. Be sure to choose Ethernet I/O that provides the following attributes:

- The ability to withstand high and low ambient temperature conditions of -40°C to +85°C (-40°F to +185°F);
- Provides channel-to-channel, case-to-channel, and channel-to-communication back plane signal isolation;
- Has a dedicated A/D converter and microprocessors for each I/O channel (Figure 1) to avoid failures of entire blocks of I/O channels as is common in I/O systems (or multiplexers) that use a single A/D converter and microprocessor for multiple channels (Figure 2);
- Has high input resolution for added accuracy for precision measurements of (> 18 bit A/D and D/A resolution);
- Is RFI/EMI protected to >20V/m to shield it from measurement errors caused by stray electrical noise. Keep in mind that RFI/EMI can penetrate right through plastic I/O module housings, so I/O systems that have metal housing are a big plus.

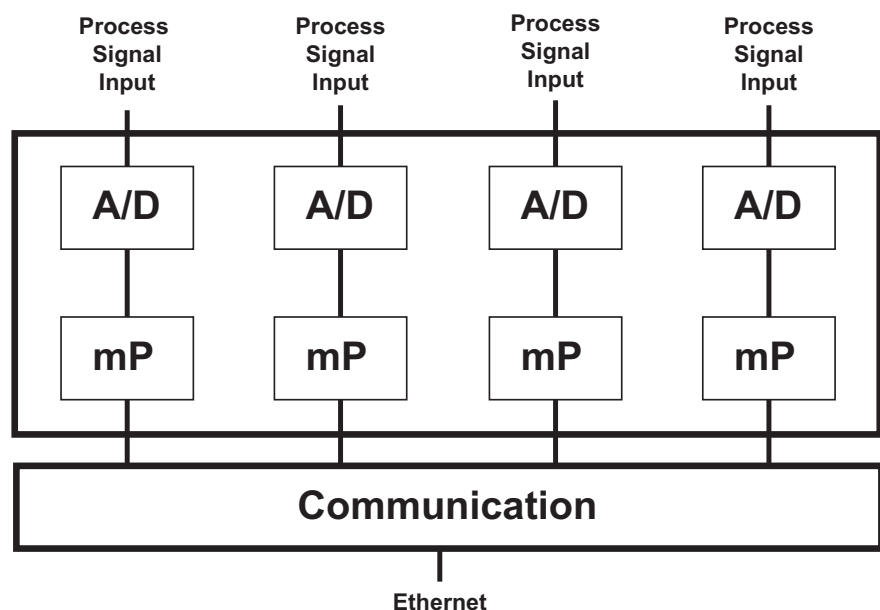
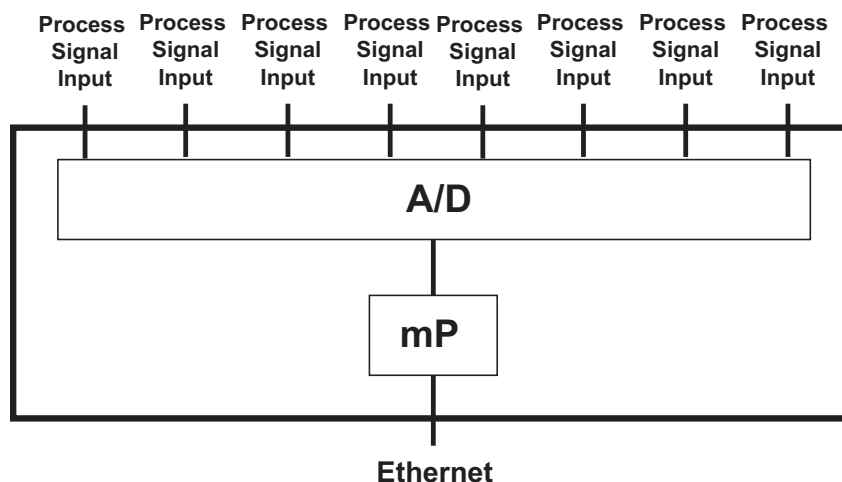

Figure 1.

Reliable I/O systems that use an individual A/D converter and microprocessor (mP) for each I/O channel avoid single points of failure because a problem with one I/O channel has no effect on any of the other channels.





**Figure 2.**

A traditional I/O multiplexer processes all of its signal inputs and outputs through a common A/D Converter and microprocessor leaving all I/O channels extremely vulnerable to single points of failure.

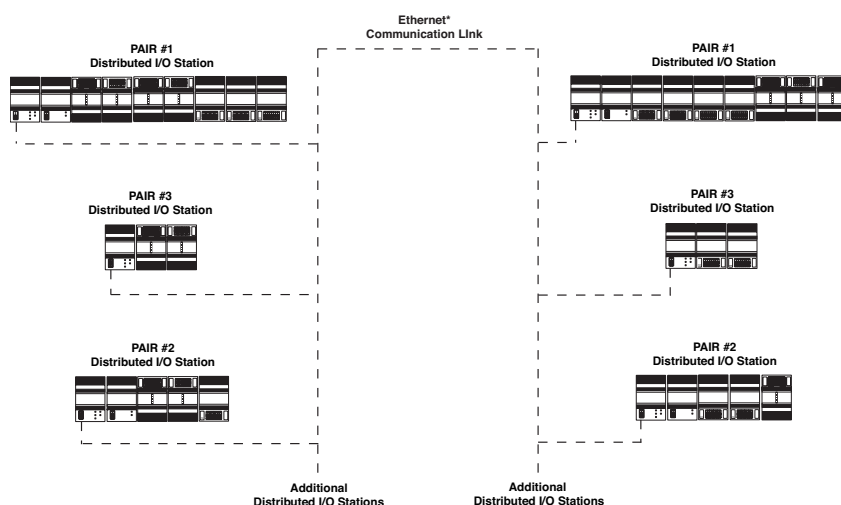

**Figure 3.**

A Peer-to-Peer distributed Ethernet I/O network can be used to economically transmit process signals between the field and control room.

### Control, Maths, and Peer-to-Peer Capability

As control capability gets pushed further into the field, specify remote I/O that has the ability to accommodate control and maths capabilities that one day might be needed. Some remote I/O vendors are implementing full fledge control capability by offering a RTOS (Real Time Operating System), RTC (Real Time Clock) and RTCE

(Real Time Control Engine) within their platforms. Maths capabilities also allow many Ethernet remote I/O systems to handle functions that were typically handled by an expensive PLC. This may include acting as a flow computer, remote terminal unit (RTU), and a high/low selector.

Peer-to-Peer communication capability with independent I/O systems is also a growing trend.

In a convenient and cost-effective way, Ethernet and fibre backbones now provide migration of signals from one side of the plant to the other (Figure 3). Some type of channel-mapping system that is inherent to the I/O system can be very useful when spare twisted pairs are no longer available.

### Ethernet I/O's Future

While securing signal integrity with the properly selected Ethernet I/O products, data integrity is every vendor and client's next imminent concern. Cybersecurity is not a new topic, but industrial vendors of Ethernet enabled products are already feverishly working towards ensuring their products cannot be accessed or manipulated by any unauthorised or rogue entity. Newer products and vendors will now be paying much closer attention to how their software is written, what standards it is written to and how much access is allowed to the product once installed at customer sites. Front end signal integrity to back end data integrity with full security is the new benchmark for all future Ethernet I/O products.

While Ethernet gives end users more power and flexibility, don't make the mistake in presuming that because it's on Ethernet, it will easily communicate with everything else that is on Ethernet.

# DYNAMIC MEASUREMENT AND CALIBRATION OF MECHANICAL SENSORS: NEW SOFTWARE



Image courtesy HBM GmbH



## Sascha Eichstädt, PTB, Ian Smith, NPL and André Schäfer from HBM discuss PyDynamic, new software which supports dynamic measurement.

Vehicle engine manufacturers are constantly seeking to improve engine efficiency and drivetrain performance to maintain a leading edge in the market.

During the design and development phases, accurate torque measurements of prototype systems are essential to evaluate and understand power transmission losses. To do this, engines and electric motors are mounted in test rigs and torque sensors are used to monitor system performance. The applied changes in torque are representative of real use and

therefore are dynamic: they change continuously over time rather than in 'ideal' steps. However, torque sensors are only calibrated using specific constant torque values that do not take the dynamic response of the sensor into account. This means that the results obtained can be unreliable and calibration procedures are therefore needed that take the dynamic response into consideration.

### Does this dynamic response problem apply only to torque measurements?

This dynamic response problem actually applies to almost all mechanical sensors. Many other mechanical parameters such as force, pressure and temperature, which are also routinely measured in industry, are dynamic too. They can have a broad frequency content and the behaviour of the measuring system is itself often strongly frequency dependent.

For example, the acceleration of an object when exposed to a force that varies with time is a dynamic

quantity and the measurement of the acceleration is therefore a dynamic measurement. Suppose that the acceleration is measured by an accelerometer, and the acceleration has appreciable frequency content close to the instrument's resonance frequency.

The output of the accelerometer will show a reverberation and a time-dependent deviation from the acceleration. As a result of the interaction between the acceleration and the accelerometer that arises from its resonant behaviour, a dynamic (frequency-dependent) model of the accelerometer is needed and a correction (in mathematical terms a deconvolution) must be applied to the output to recover the measured acceleration.

This correction is analogous to correcting for systematic effects in static or steady-state measurements, and without it the accelerometer provides unreliable information. In both static and dynamic cases it is necessary to include the measurement uncertainty appropriate to the correction.



## New open-source software for analysing dynamic measurements

Until now, although National Metrology Institutes (NMIs) and accredited laboratories can provide calibration services for dynamic sensors, there has been a distinct lack of guidance on how industry can use this information within their own dynamic measurement applications to improve the understanding of measurement results. Software that demonstrates the guidance in action is key for industry to implement and benefit from dynamic calibrations.

Working together, the Physikalisch-Technische Bundesanstalt (PTB) in Germany and the National Physical Laboratory (NPL) in the UK have developed PyDynamic to meet this requirement. PyDynamic is open-source software implemented in Python to support the dynamic calibration of sensors and the subsequent use of those sensors in dynamic measurement problems.

It provides functions for applying the discrete Fourier transform and its inverse, designing and using finite-impulse response or infinite-impulse response filters having uncertain coefficients, convolution and deconvolution in the frequency domain, and transformation between amplitude-phase and real-imaginary representations. These functions are some of the basic building blocks of signal processing and used routinely by engineers.

But what makes PyDynamic really useful for industry is that the available functions include by default, the propagation of measurement uncertainty from their inputs to their outputs. This allows dynamic measurements to be made traceable to the signal input, just as static measurements can be made traceable. Also, it comes with detailed examples showing how it can be used in practice. And PTB and NPL are not stopping there but will keep improving and extending PyDynamic to put state-of-the-



Image courtesy HBM GmbH

art NMI methods in the hands of engineers in industry.

## Applications of PyDynamic

PyDynamic is versatile. It has been applied in real measurement problems, including the calibration of accelerometers using a high-intensity shock, compensation for the hysteresis effects of piezoelectric fibre optic sensors, analysis of signals measured by medical ultrasound devices, and study of invasive blood pressure measurements. As an example, the German company Hottinger Baldwin Messtechnik (HBM) GmbH, a world market leader in testing, measuring and weighing technology, used PyDynamic to test conditioning amplifiers to reveal that not all signals produced by the connected transducer were registered as expected, leading to potential response errors. By improving their signal analysis technique, HBM have now upgraded the firmware for the amplifier and created a product Quantum MX410B which is reliable and accurate over a wide frequency range suitable for dynamic measurements.

For more information about the technical work, contact Sascha Eichstädt, PTB (Germany) (Sascha.Eichstaedt@ptb.de), Ian Smith, NPL (UK) (Ian.Smith@npl.co.uk) or André Schäfer, HBM GmbH (Germany) (andre.schaefer@hbm.com), or go to the web site [empir.npl.co.uk/dynamic/](http://empir.npl.co.uk/dynamic/). The software package PyDynamic can be accessed via the PyDynamic GitHub website [github.com/eichstaedtPTB/PyDynamic](https://github.com/eichstaedtPTB/PyDynamic). This work is part of the Joint Support for Impact project 14SIP08 of the European Metrology Programme for Innovation and Research (EMPIR). The EMPIR is jointly funded by the EMPIR participating countries within EURAMET and the European Union.

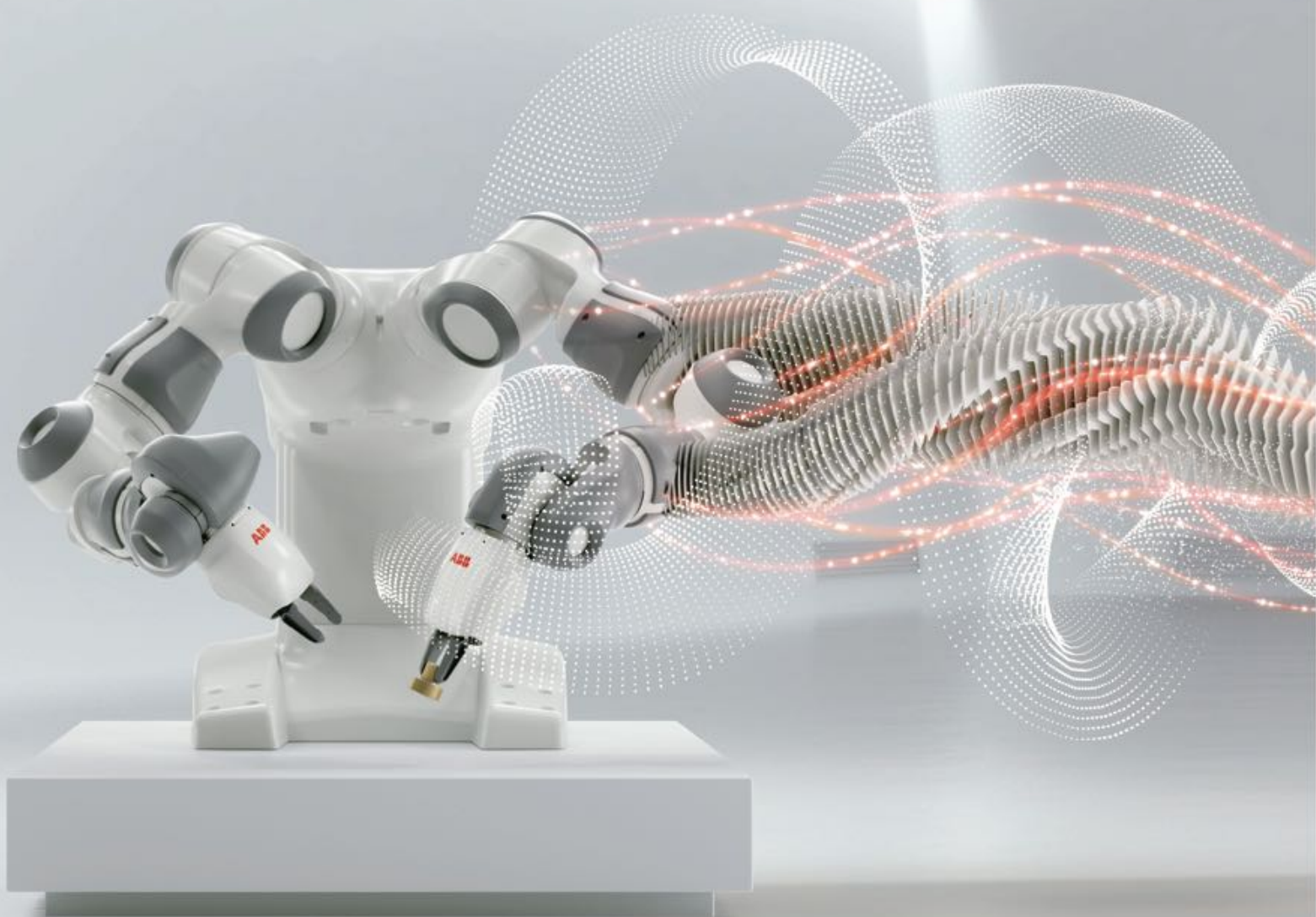

---

## Making collaboration a reality

Meet YuMi®, short for you and me

Meet YuMi, the assembly, inspection and testing robot solution that will help robots and humans work together to create a smarter future for UK manufacturing. Providing greater throughput, accuracy and repeatability, YuMi advances robot technology to allow humans to focus on equally important tasks such as programming, management and creativity. To find out more about YuMi's capabilities, visit <http://bit.ly/YuMiInstMC>

**ABB**



# STRONG M&A MARKET ROGER BUCKLEY, CORPORATE FINANCE PARTNER, BDO LLP SAYS THE FEEL GOOD FACTOR CONTINUES

The second quarter of 2018 saw 642 deals complete in the UK, a notable increase from last quarter's 560 deals and a rise of 7% compared with the same period last year, according to the latest analysis from accountancy and business advisory firm BDO LLP.

The M&A market is strong, populated by a large number of corporates and private equity eager to acquire a comparatively small population of high quality businesses. These dynamics are pushing up valuations and driving increases across all three

indices. The analysis reveals that a higher number of transactions are attracting double-digit multiples across the board.

BDO's Private Company Pricing Index and Private Equity Pricing Index (PCPI and PEPI) quarterly report shows a significant increase in the volume of Private Equity ("PE") transactions: 121 completed in Q2, the highest number for two years. The increase in PE transactions represents a 64% increase on the first quarter of 2018, and 32% increase on the second quarter of 2017. In total, 521 trade transactions were recorded in the second quarter: an increase of 7% on the previous quarter and a moderate increase on the same quarter of 2017.

Alongside climbing volumes, the second quarter of 2018 saw valuations rising, with both the PCPI and PEPI seeing impressive upticks. These indices, which track the EV/EBITDA multiples paid by trade and private equity buyers for private companies, underline the health of the current M&A market. The PCPI increased to 11.6x, the highest

recorded since the last quarter of 2014, and the PEPI increased to 13.5x, the highest recorded for seven years.

## **Test & Measurement second quarter deals: using M&A to build strong platforms**

Market optimism was equally reflected in the Test & Measurement sector in the second quarter, which was another busy quarter for deals. A number of the big US consolidators, including Thermo Fisher and Emerson, took advantage of opportunities to complete big ticket transactions to bulk up operations.

Thermo Fisher acquired Gatan, a subsidiary of Roper Technologies, for US\$925m. US-based Gatan is a manufacturer of instrumentation and software used to enhance and extend the operation and performance of electron microscopes. It will boost Thermo Fisher's existing electron microscopy portfolio and create an integrated system that connects microscope hardware, software and accessories.

Meanwhile, Emerson agreed to acquire the Tools & Test business of Textron for US\$810m. Tools & Test is a leading manufacturer of electrical and utility tools, diagnostics and test & measurement instruments, with global brands including Greenlee and Klauke. Together with Emerson's Ridge Tool Company, the acquisition creates a global US\$1bn professional tools business targeted to mechanical, electrical and plumbing contractors.

Alongside corporates, private equity continue to build platforms in the Test & Measurement market. An example is Battery Ventures, which has established a number of platforms targeted to different sub-sectors, and regularly acquires to build these into global groups of leading technologies and brands.

Process Sensing Technologies (PST) is Battery's platform in the process measurement market, which has seen swift development through

recent investments both in the UK and abroad. Created following the acquisition of UK-based Michell Instruments in 2016, PST added California-based Analytical Industries in 2017, a manufacturer of electrochemical oxygen sensors and gas-analysis products. The acquisition of Rotronic AG, a Swiss manufacturer of humidity and temperature measurement solutions, followed later in the year. PST continued its spree in 2018 with the acquisition of LDetek, a Canadian manufacturer of gas chromatography instruments and online analysers, and most recently added UK businesses Dynament and Status Scientific Controls, manufacturers of infrared gas detection sensors and instruments.

BDO advised on the sales of Dynament & Status Scientific, sister companies based in Mansfield with significant global customer bases, to PST. The companies' founder will continue to be involved in the

businesses as Chairman, and the existing executive teams will remain and work closely with PST group's CEO Adam Markin. Joining PST will provide the businesses with many valuable resources as they continue to grow and develop globally.

Roger Buckley, M&A Partner at BDO, commented: "Private equity has plenty of cash to deploy, and international investors are continuing to make significant investments in the UK, creating positive outcomes for sellers and encouraging deals to come to market. We see continuing confidence in the M&A market especially for quality businesses and expect 2018 to continue to be a strong year for deal making."

# Functional Safety 2018

## InstMC FS 1-Day Briefing Event Hints, Tips & Pitfalls

**Date:** Wednesday 21st November 2018

**Location:** The Centre, Birchwood Park,  
Warrington, WA3 6YN



Main Sponsor

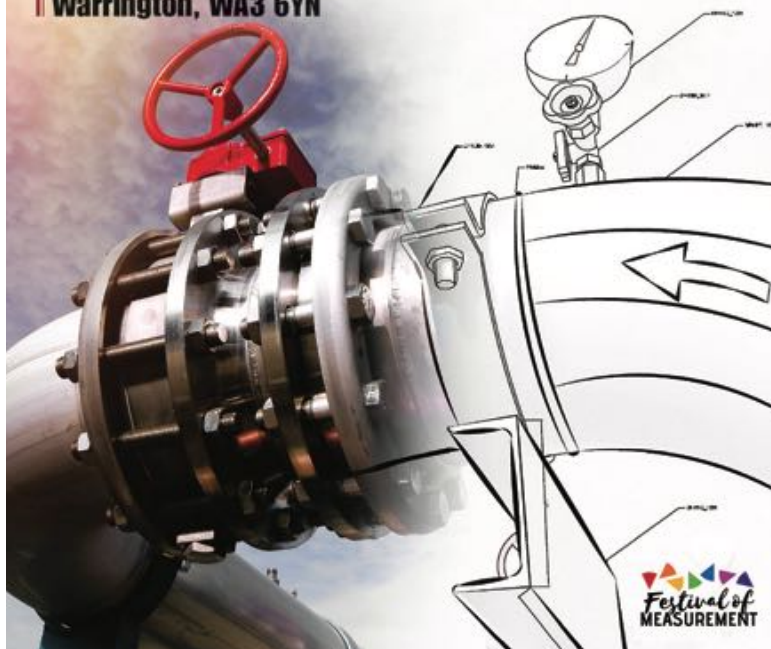

This event is designed to brief the end user on good practice in Functional Safety. Recognised authorities will provide concise briefings focussed on distinct aspects of functional safety. Each briefing will be followed by a Q&A panel session in which the experts will respond to questions from the audience. An awareness of the Functional Safety principles will be assumed. Briefings will cover:

- SIL Determination, Tolerable Risk & ALARP
- SIF Design & Compliance Evaluation
- SIS Product Selection
- SIS Cyber Security
- SIS Operation & Maintenance
- Professional Development with the InstMC

The briefings will all be unbranded and non-commercial. They will not promote any proprietary solutions but will identify possible approaches, the associated pros and cons, and the traps to avoid. A concurrent exhibition will allow exploration of a range of related vendor offerings in the Functional Safety arena.

**Cost of this event is: £295 + VAT Non Member/  
£250 + VAT Members**

For more information and to book your place at this event please contact [www.instmc.org](http://www.instmc.org) or call 020 7387 4949

# WHY THE NEW EPRIVACY REGULATION MUST BE ON YOUR CORPORATE RADAR



Now that the hype and fury over the new General Data Protection Regulation (GDPR) has died down, businesses will have to get their heads around another European Union edict, by the end of 2018 or early 2019, in the shape of the ePrivacy Regulation (ePR).

Allotts, which has had a busy year guiding businesses through the GDPR compliance process, is now turning its attention to highlighting the scope of this new privacy regulation. Although ePR has received less publicity than GDPR to date, compliance with it is non-negotiable. Those suffering from GDPR fatigue have little time to rest on their laurels and need to be ready to tackle this new legal framework head-on if they are to avoid hefty fines for non-compliance.

GDPR evolved from the Data Protection Act (DPA) so it's no surprise that ePR has morphed out of another previous EU incarnation, the Privacy and Electronic Communication Regulations (PECR) - more commonly known as the Cookies Law. The ePR will, however, have a much broader scope than just beefing up the rules on cookies and getting rid of pop-up consent boxes

in favour of user-friendly browser settings.

It will target how personal data is used in the context of new electronic communications channels and is expected to encompass such areas as 'Over the Top' (OTTs), which includes instant and social media messaging services - think WhatsApp, and 'Voice Over Internet Protocol' providers (VoIPs) like Skype, which will fall under the same EU laws as telephone calls, email communications and SMS messages. The goal of ePR is to control consents more rigidly for both the content of the communications and the metadata<sup>1</sup> attached to those communications.

Much of ePR will dovetail with GDPR - the fines will be aligned - so getting to the bottom of what's permissible under Legitimate Interests is key, and how to obtain



and manage consent across social media and various other media platforms is something businesses need to address as a priority.

Philip Allott, managing director of Allott and Associates, who is both legally and GDPR qualified, believes many businesses have paid scant attention to PECR so far and will be prone to the same almost mass hysteria when the ePR deadline date to comply is announced, because this new regulation will be enforced just as rigidly.

He said: "With further legislation planned for later this year, the first of which is likely to be the ePrivacy regulation, I'd advise companies to take it just as seriously as GDPR and to prepare early. We have already helped thousands of businesses become compliant with GDPR and, as this sister legislation cannot be overlooked, we would encourage people to talk to us about the new guidelines. Otherwise, failing to prepare could mean preparing to fail in this case."

No matter how one views regulations issued from Brussels or Westminster, never forget that these rules are designed to enforce all its citizens' rights to confidentiality, and protect them from the nightmare of personal data falling into the wrong hands. Even if their information is in the right hands, it gives them the power to have their data amended or deleted, usually without argument, if they so desire.

If your business has not yet started its ePR compliance journey and it needs some professional support, then book a place on one of our training courses later this year by calling 01423 867264 or for more information visit [www.allottandassociates.co.uk](http://www.allottandassociates.co.uk).

#### Notes

1. Metadata = data processed by the electronic communications network for the purpose of transmitting, distributing and exchanging the content.

## Background Information

Allott & Associates Ltd is an award-winning full-service agency and provides all the services you would expect from an in-house marketing department. Established for over 20 years, Allott & Associates Ltd has the marketing resources, experience and determination to help your organisation attain its strategic objectives.

Currently the agency is proactively involved in marketing campaigns in the UK, mainland Europe, Turkey, the US and Australia.

Many of the company's clients are involved in business-to-business (B2B) activities including food, beverages, packaging, electronics, engineering, logistics, pharmaceuticals and printing together with numerous related markets. The company is also experienced in providing marketing support to a number of service sectors, including education, local and central government, the MOD and the facilities management sector.

Key marketing services provided by Allott & Associates Ltd include public relations, social media, GDPR compliance, design, marketing consultancy, photography, advertising, direct-mail, website development, research, exhibition support, corporate events and film making.

For 2018, the agency is offering a fully automated marketing service. This service allows companies to send emails and graphics that are diary scheduled over a few days, weeks or even months. The recipient's behaviour is monitored and depending on their response another email will be sent asking if they would like a phone call. The most enthusiastic of the email recipients, typically 5% who have clicked and read everything, are scheduled by Automatic Marketing as warm leads for the company's sales team.

In addition to its core marketing activities, Allotts is providing businesses with full GDPR compliance support. The agency provides GDPR audits, drafting of privacy statements, DPO support, in-house staff training and full or half day bespoke training courses resulting in a practical plan of action that businesses can implement themselves.

For more information and a bespoke quotation on any aspect of our business, please give Allott & Associates Ltd a call on +44 (0)1423 867264 or visit the website at [www.allottandassociates.co.uk](http://www.allottandassociates.co.uk).

For editorial or sales enquiries please contact:

Carol Rees or Philip Allott  
Allott & Associates Ltd  
Claro Chambers, 42 High Street  
Knaresborough  
HG5 0EQ.  
Tel: (01423) 867264  
or Fax (01423) 869140

Email:  
[carol@allottandassociates.co.uk](mailto:carol@allottandassociates.co.uk)

Website:  
[www.allottandassociates.co.uk](http://www.allottandassociates.co.uk)

Follow Allott and Associates on twitter @AllottsPR and linkedin and like our facebook page.

# OUR CORE TEAM

## OFFICERS

**President**  
Professor Graham Machin



**Honorary Treasurer**  
Colin Howard



**Honorary Secretary**  
Dr Graeme Philip



**Engineering Director**  
Dr Maurice Wilkins



**Chief Executive  
Officer**  
Patrick Finlay

Tel: +44 (0)20 7387 4949  
patrick.finlay@instmc.org



**Head of Operations**  
Aytan Malka

Tel: +44 (0) 20 7387 4949 Ext 6  
communications@instmc.org



**Communications &  
Marketing Executive**  
Ernest Kyei

Tel: +44 (0) 207 387 4949 Ext 5  
ernest.kyei@instmc.org



**Professional Registration  
and Membership Manager**  
Leila Atherton

Tel: +44 (0) 20 7387 4949 Ext 7  
membership@instmc.org



**Bookkeeper and  
Subscriptions Manager**  
Roy Ginn

Tel: +44 (0) 20 7387 4949 Ext 7  
accounts@instmc.org



**IT Support  
(Trailblazer Apprentice)**  
Aaron Leigh

Tel: +44 (0) 20 7387 4949 Ext 6  
aaron.leigh@instmc.org



**Head of Communications  
& Marketing**  
Stephanie Smith

Tel: + 44 (0) 207 387 4949 Ext 3  
steff.smith@instmc.org



**Membership Support Officer**  
James Sinton

Tel: +44 (0) 20 7387 4949 Ext 4  
admin-subs@instmc.org



**Digital Marketing  
Assistant**  
Sydney Reed  
sydney.reed@instmc.org





**excellence in** *Dependable Automation*

# Experienced. Efficient. exida.

Helping the process industry cost-effectively implement the requirements for **Functional Safety** and **Industrial Cybersecurity** standards and **Alarm Management** through **Training, Consulting, and Engineering Tools**.

exida UK  
Lake View House  
Tournament Fields  
Warwick  
CV34 6RG  
UK

Phone: +44 (0)1926 676125

[www.exida.co.uk](http://www.exida.co.uk)



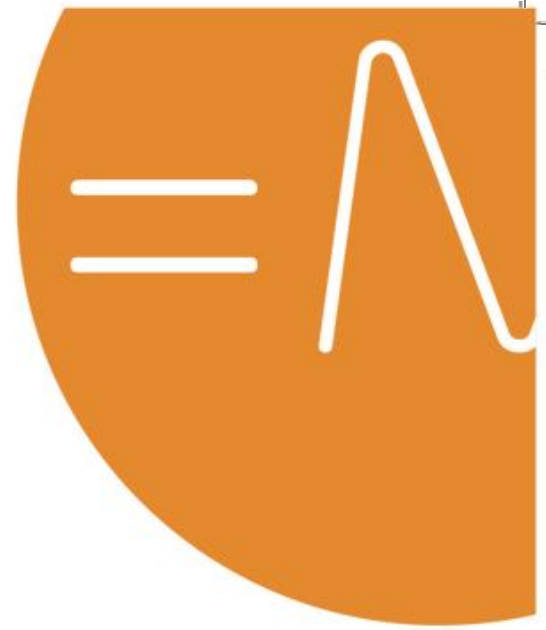

# Most Engineers responsible for Control and Safety System Cyber Security are not IT experts

...And you don't need to be. But you do need to know what is expected of you by the new regulations and how to implement effective and appropriate systems for managing your cyber security risks.

[www.methodcysec.com/training-near-me/](http://www.methodcysec.com/training-near-me/)

**=Method** | We do this  
Cyber Security every day

p: 01462 713313

e: [support@methodcysec.com](mailto:support@methodcysec.com)

w: [www.methodcysec.com](http://www.methodcysec.com)